



CW³ 6000M-DL

Automatic Checkweigher

www.loma.com

Versatile, proven DragLink checkweighing systems for the food and packaging industries



- **Versatile** Weighs a wide range of flexible and rigid packs up to 6kg
- **Accurate** Excellent accuracy, especially with flexible packaging
- **Fast** Belt speeds up to 120m/min
- **Reliable** Heavy duty conveyor components, high quality electronics
- **Accredited** OIML R51 and EC TAC (MID) approved
- **Easy to use** Full colour graphical touch screen
- **Environment** Wide operating temperature range 0-40°C

Metal Detection

X-ray Inspection

Checkweighers

Data Capture

Designed to Survive



CW³ 6000M-DL Automatic Checkweigher

Finish:	304 stainless steel with bead blast finish
Available Line Heights:	700mm - 1200mm
Weigh Table Length:	610mm
Maximum Weight:	6kg
Maximum Product Width:	300mm
Maximum Product Length:	400mm
Typical Accuracy, Un:	0.6g
Maximum Speed:	120m/min
Capacity:	440ppm
Supply Voltages:	110 or 230V/1ph/N+E 50 or 60Hz
Air Supply:	5 to 8 bar
Typical Reject Options:	Air Blast, Pusher, Diverter
Environment:	IP65
Belt type:	Food quality flat belt - quick release (no tools required)
Standard inclusions:	Adjustable feet, Reject bin, USB socket, Multi speed, Pack pitch monitor, LED indicator stack
Options:	Servo feedback signal - for filler control, Serial Link, LomaEnet, 316 stainless steel

Technical Specification

- Stainless steel construction
- Application specific filtering
- Automatic mean weight correction
- Sample packs function
- Multi-product memory (500)
- Brushless motors
- High capacity loadcell
- True multi-speed
- R51/MID Approved to X(1) e = 1g

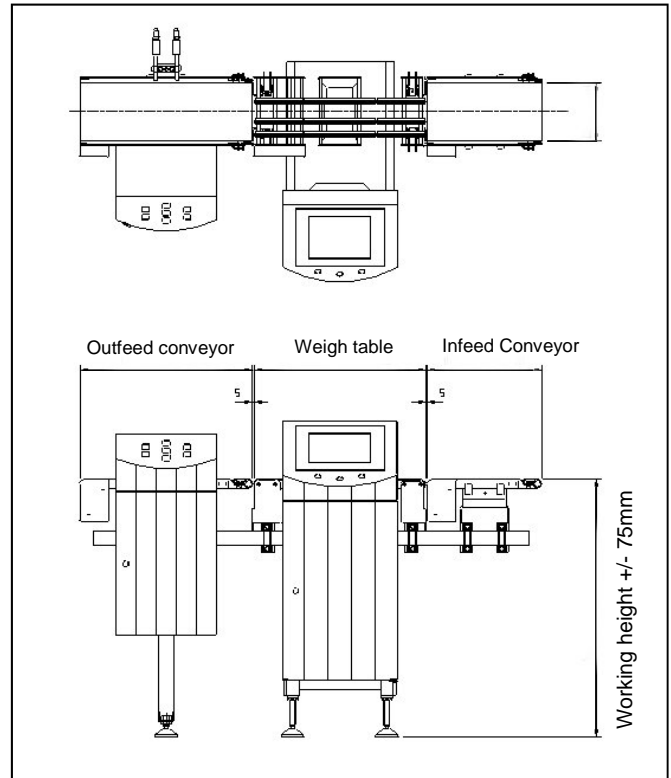

Loma Systems, Summit Ave, Southwood, Farnborough, Hampshire, GU14 0NY

Tel: +44 (0)1252 893300

Fax: +44 (0)1252 513322

Email: sales@loma.co.uk