



CW³ Checkweigher / Metal Detector Combination System

www.loma.com

Versatile, proven integrated combination checkweighing and metal detection systems for the food and packaging industries



- **Adaptable** True variable frequency detection adapts to new product and packaging in seconds
- **Versatile** Weighs a wide range of flexible and rigid packs up to 6kg
- **Accurate** Excellent accuracy, especially with flexible packaging
- **Compact** Integrated to save line space
- **Reliable** Heavy duty conveyor components, high quality electronics
- **Effective** Loma expertise in both technologies ensures maximum system performance
- **Easy to use** Integrated colour graphical touch screen
- **Accredited** OIML R51 and EC TA (MID) approved

Metal Detection

X-ray Inspection

Checkweighers

Data Capture

Designed to Survive



CW^B Checkweigher / Metal Detector Combination System

Finish:	304 stainless steel with bead blast finish
Available Line Heights:	700mm - 1,200mm
Available System Lengths:	1,900mm - 2,900mm
Maximum Weight:	1,500g
Maximum Product Width:	300mm
Maximum Product Length:	425mm
Typical Accuracy, Un:	0.6g
Maximum Speed:	120m/min
Capacity:	400ppm
Supply Voltages:	110 or 230V/1ph/N+E 50 or 60Hz
Air Supply:	5 to 8 bar
Typical Reject Options:	Air Blast, Pusher, Diverter
Environment:	IP65
Belt type:	Food quality flat belt - quick release (no tools required)
Standard inclusions:	Adjustable feet, Reject bin, USB socket, Multi speed, Pack pitch monitor
Options:	Servo feedback signal - for filler control, Serial Link, LomaEnet, PVS, LED Indicator stack, 316 stainless steel

Technical Specification

Stainless steel construction
Multi-product memory (100)
Brushless motors
True multi-speed
Application specific filtering
Sample packs function
Automatic mean weight correction
High capacity loadcell
R51 Approved to X(1) e = 1g
PVS - performance validation system
Aperture heights
75mm - 250mm in 25mm increments
Aperture widths
150mm - 350mm in 100mm increments

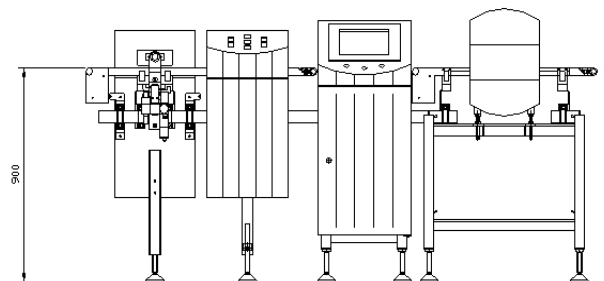
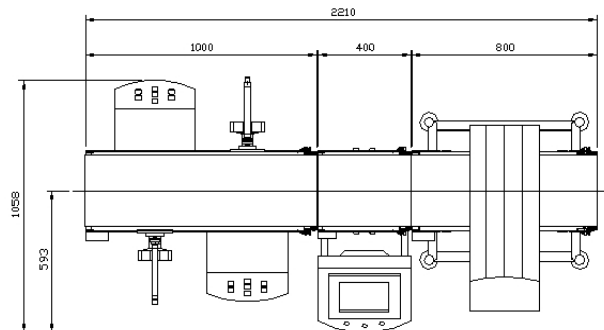

Typical Dimensions

Loma Systems, Summit Ave, Southwood, Farnborough, Hampshire, GU14 0NY

Tel: +44 (0)1252 893300

Fax: +44 (0)1252 513322

Email: sales@loma.co.uk