



IQ⁺ Pharmaceutical Metal Detection

www.loma.com

Versatile, proven metal detection systems for the pharmaceutical industry with full colour graphical touch screen.



- **Compact** Installed easily and quickly after the de-duster or tablet press
- **Safe** The failsafe reject mechanism ensures precise rejection of contaminated product
- **Sensitive** Advanced signal processing provides unsurpassed levels of detection
- **Hygienic** Product contact parts can be quickly dismantled and cleaned
- **Reliable** Robust design ensures long, reliable performance on the line

Metal Detection

X-ray Inspection

Checkweighers

Data Capture

Designed to Survive



IQ⁺ Pharmaceutical Metal Detection

Finish:	304 stainless steel with bead blast finish		
Aperture Sizes:	100mm x 20mm	100 x 38mm	
Supply Voltage:	110/115/200/220/230V 50/60Hz		
Input Height:	530mm to 835mm		
Output Height:	240mm to 680mm		
Height Adjustment:	Gas strut assisted		
Tilt Angle:	45° maximum		
Reject Type:	High speed electrical solenoid driven flap		
Throughput:	Up to 10,000 tablets/min		
Cleaning Regime:	Wipe/blow machine Wash inlet/outlet chutes		
Options:	Beacon stanchion Ethernet	Keyboard cover Remote reports	LomaEnet Serial link PVS Beacon

Technical Specification

- Upgradeable metal detector controls
- PVS to aid HACCP compliance
- Various communication options to suit plant integration protocols
- Direct transmitter drive to eliminate thermal drift
- High field strength to eliminate external interference and deliver the ultimate in noise free detection
- 32-bit digital signal processing for enhanced contaminant detection
- Standard apertures on rapid delivery
- 1MHz operating frequency for peak high-grade stainless steel detection

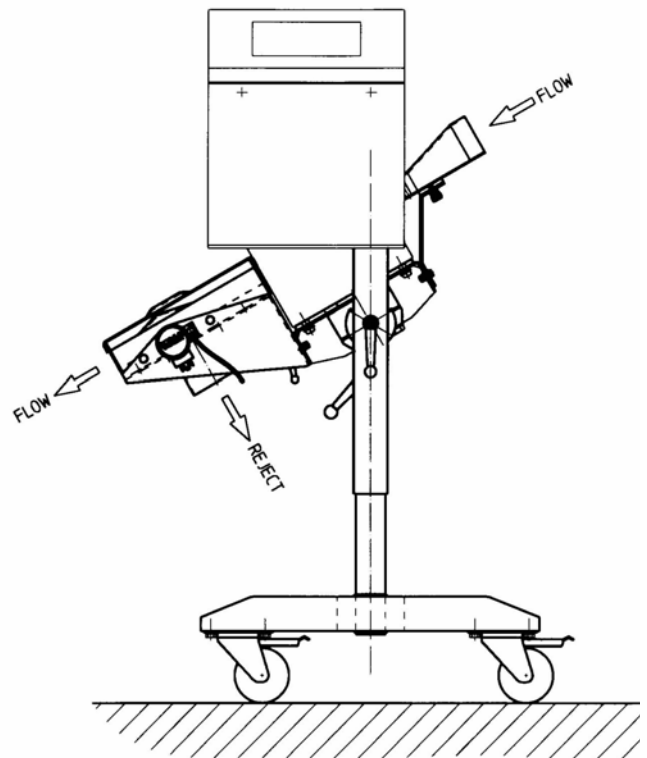

Loma Systems, Summit Ave, Southwood, Farnborough, Hampshire, GU14 0NY

Tel: +44 (0)1252 893300

Fax: +44 (0)1252 513322

Email: sales@loma.co.uk