



LomaNet Reports Capture System

www.loma.com

Ethernet Reports Capture System for the Loma range of products



- **Versatile** Report capture software delivering valuable product data to network PC's
- **Easy to use** User friendly Windows environment
- **Rapid Payback** Identify give-away and control the process
- **Flexible** Easily connect existing or new Loma equipment onto an Ethernet network
- **Efficient** Eliminate paper records and data entry, for HACCP and Weight compliance

Metal Detection

X-ray Inspection

Checkweighers

Data Capture

Designed to Survive



Reports Capture Systems

Cable: Standard CAT5
 PC: Shared
 Operating System: Windows XP
 Number of devices: ≤ 40
 Device compatibility: IQ², IQ³ and IQ³⁺ Metal Detectors
 6000/7000, AS, LCW and CS4000
 Checkweighers
 X³ & X⁴ X-ray Systems
 Maximum cable length : Network limited

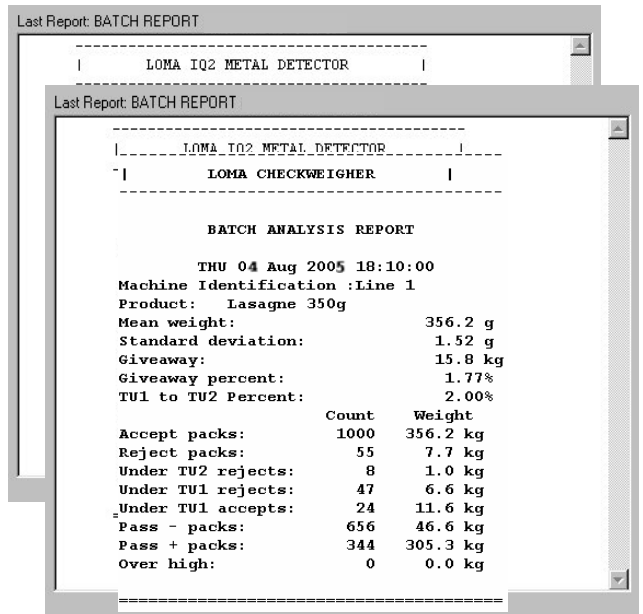

Typical Network Configurations

Existing Ethernet Plant Network

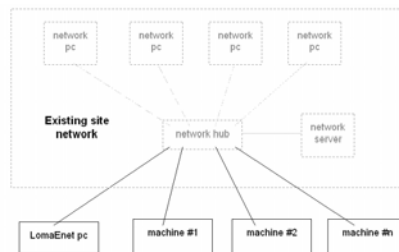

Mini-Network (no existing plant network)

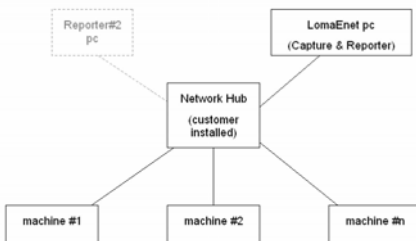

Integral Mini-Hub Network (>1 device per line)

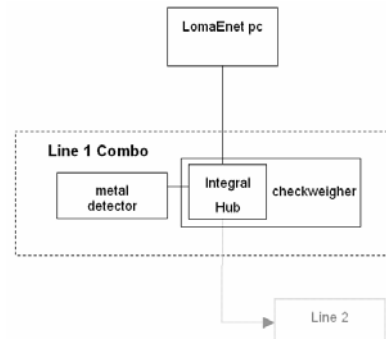

Loma Systems, Summit Ave, Southwood, Farnborough, Hampshire, GU14 0NY

Tel: +44 (0)1252 893300

Fax: +44 (0)1252 513322

Email: sales@loma.co.uk

Designed to Survive