



X-Weigh Inspection Systems

www.loma.com

Combined X-ray and checkweighing for the food and packaging industries



- **Versatile** Contaminant inspection and checkweighing in one fully integrated system
- **Easy to use** Single intuitive full colour touch-screen for both applications
- **Sensitive** Auto calibration, which requires no programming and maximizes performance
- **Accurate** Accuracy comparable with traditional checkweighers
- **Fast** Belt speeds up to 70 m/min with optimum performance

Metal Detection

X-ray Inspection

Checkweighers

Data Capture

Designed to Survive



X-ray Inspection Systems

- Finish: 304 stainless steel with brushed finish
- Typical Line Height: 900mm ± 50mm
- Typical Length: 2500mm
- Belt Width: 300/500mm
- Supply Voltages: 230/1ph/50Hz N+E or 110/1ph/60Hz N+E
- Air Supply: 5 to 8 bar
- Reject Options: Air Blast single or twin, Pusher others to order
- Environment: IP 55
- Belt Type: Flat (food quality) belt
- Standard Inclusions: Height adjustable feet, Mass Measurement, Missing product, Image and report archiving, Hinged interlocked covers, Variable speed
- Options: Reject confirmation, Bin full sensing, Reject bin, Survey meter, Remote diagnostics, Lockable wheels, LomaEnet, Washdown Upgrade

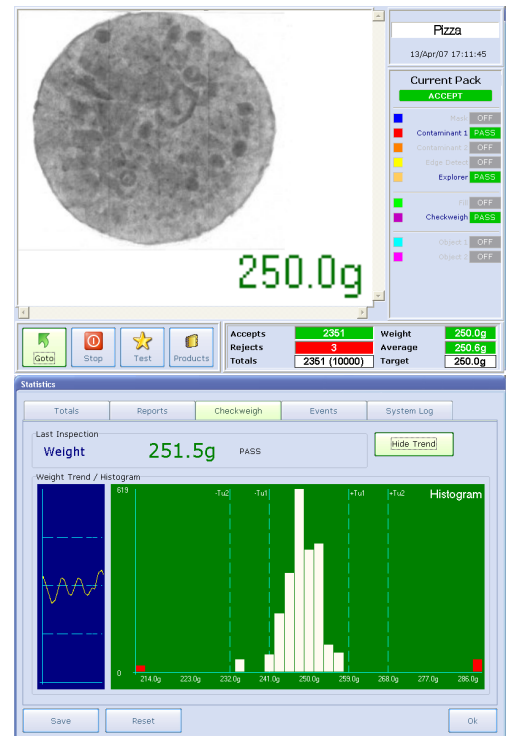

Technical Specification

- Industrial Grade PC with modem, Ethernet and front access USB port
- Embedded Windows XP operating system
- Digitally controlled WASC (Wide Angle, Self Cooled) high performance X-ray tank. (Tube life estimated at 7 to 10 years)
- Unique USB high speed, high stability, detector array with 0.8mm diode pitch.
- Computer vision system utilising image processing and morphological techniques
- Pass Key protected set-up
- USB Report and image archiving
- Full diagnostic and system health monitoring with date and time stamp archiving, including remote support tools
- Usage monitoring with planned maintenance prompts
- Modular system with speed digital communications between major components

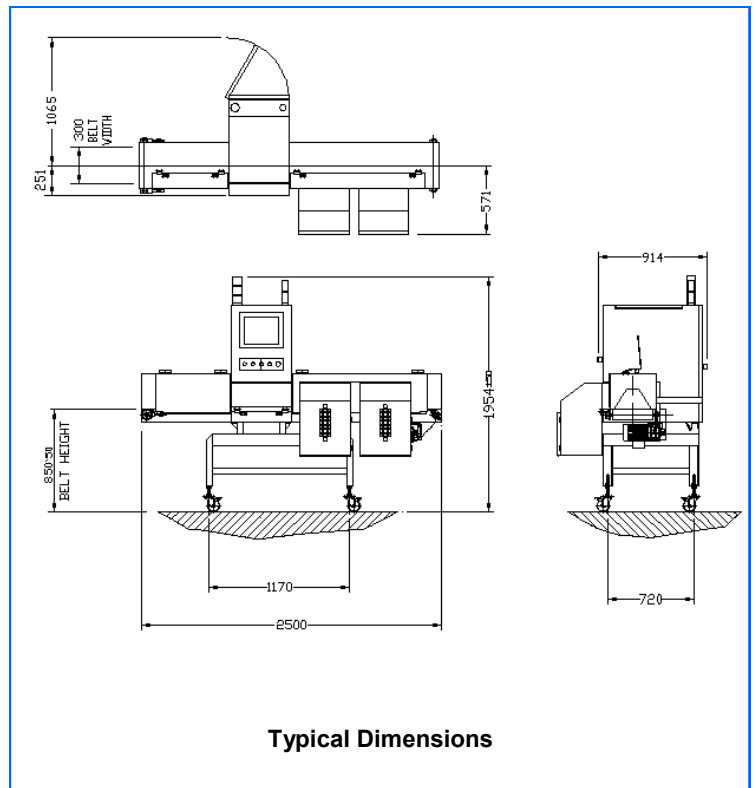

Typical Dimensions

Loma Systems, Summit Ave, Southwood, Farnborough, Hampshire, GU14 0NY

Tel: +44 (0)1252 893300

Fax: +44 (0)1252 513322

Email: sales@loma.co.uk

