



X⁴ 300 FinePitch X-ray Inspection Systems

www.loma.com

Versatile, proven X-ray detection for the food and packaging industries



- **Versatile** Models and reject systems to suit a wide range of packaged product
- **Easy to use** Intuitive full colour touch-screen
- **Sensitive** High performance, auto configuring contaminant detection algorithms
- **Fast** Belt speeds up to 50m/min with optimum performance
- **Reliable** Heavy duty conveyor components, built for 24/7 operation

Metal Detection

X-ray Inspection

Checkweighers

Data Capture

Designed to Survive



X-ray Inspection Systems

- Finish: 304 stainless steel with bead blast finish
- Typical Line Height: 900mm ± 50mm
- System Length: 2000mm
- Belt Width: 300mm
- Supply Voltages: 230/1ph/50Hz N+E or 110/1ph/60Hz N+E
- Air Supply: 5 to 8 bar
- Reject Options: Air Blast single or twin, Pusher others to order
- Environment: IP 55
- Belt Type: Flat (food quality) belt
- Standard Inclusions: Height adjustable feet, Mass Measurement, Missing product, Shape recognition, Image and report archiving, Hinged interlocked covers, Variable speed
- Options: Reject confirmation, Bin full sensing, Reject bin, Survey meter, Remote diagnostics, Lockable wheels, LomaEnet, Washdown upgrade

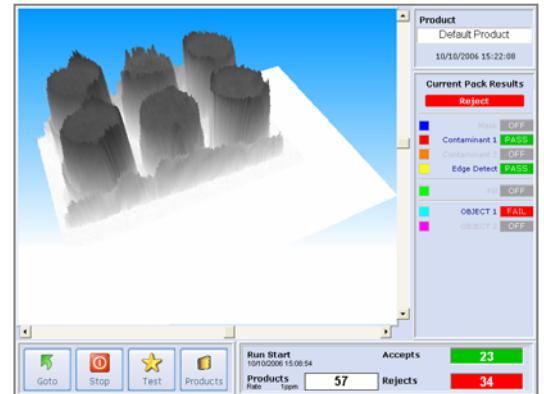

Technical Specification

Industrial Grade PC with modem, Ethernet and front access USB port

Embedded Windows XP operating system

Digitally controlled WASC (Wide Angle, Self Cooled) high performance X-ray tank. (Tube life estimated at 7 to 10 years)

Unique USB high speed, high stability, detector array with 0.4mm diode pitch

Computer vision system utilising image processing and morphological techniques

Pass Key protected set-up

USB Report and image archiving

Full diagnostic and system health monitoring with date and time stamp archiving, including remote support tools

Usage monitoring with planned maintenance prompts

Modular system with speed digital communications between major components

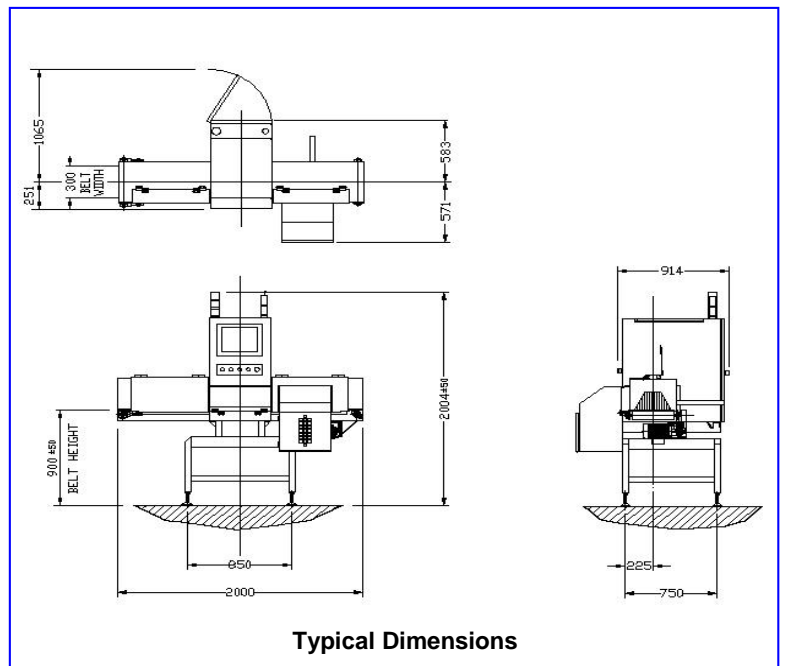

Loma Systems, Summit Ave, Southwood, Farnborough, Hampshire, GU14 0NY

Tel: +44 (0)1252 893300

Fax: +44 (0)1252 513322

Email: sales@loma.co.uk

Designed to Survive