



X⁴ PipeLine X-ray Systems

www.loma.com

Versatile and proven X-ray detection for the food process industry



- **Versatile** Range of pipe diameters to suite a wide range of free flowing product
- **Easy to use** Intuitive full color touch-screen
- **Sensitive** Each product run is independently analyzed with its own inspection profile
- **Fast** Throughput speeds in excess of 10T/hr without loss in performance
- **Reliable** Heavy duty components, high quality electronics, waterproof to IP66

Metal Detection

X-ray Inspection

Checkweighers

Data Capture

Designed to Survive



X-ray Inspection Systems

- Finish: 304 stainless steel with bead blast finish
- Typical Line Height: 1050mm ± 100mm 41" ± 4"
- System Length: 850mm (without reject) 33"
- Pipe Diameter: 64mm or 75mm (2.5" or 3")
- Supply Voltages: 230/1ph/50Hz N+E or 110/1ph/60Hz N+E
- Air Supply: 5 to 8 bar 80 to 100 psi
- Reject Options: ARC valve, signal only, others to suit
- Environment: IP 66 NEMA 4X
- Fittings: RD80, Tri-clamp, + range of adaptors
- Standard Inclusions: Adjustable feet, Remote Reports, Hinged interlocked covers
- Options: Variable speed tacho, Clip Inhibit, Survey meter, Remote diagnostics, Lockable wheels.

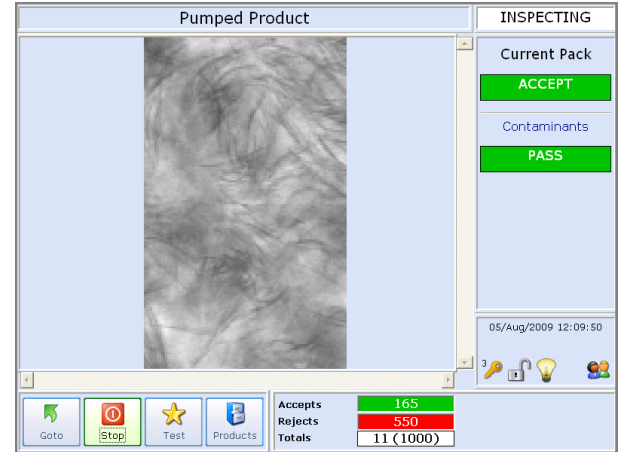

Technical Specification

Industrial Grade PC with modem, Ethernet and front access USB port

Embedded Windows XP operating system

Digitally controlled WASC (Wide Angle, Self Cooled) high performance X-ray tank. (Tube life estimated at 7 to 10 years)

Unique USB high speed, high stability, detector array with 0.8mm diode pitch

Computer vision system utilising image processing and morphological techniques

Pass Key protected set-up

USB Report and image archiving

Full diagnostic and system health monitoring with date and time stamp archiving, including remote support tools

Usage monitoring with planned maintenance prompts

Modular system with speed digital communications between major components

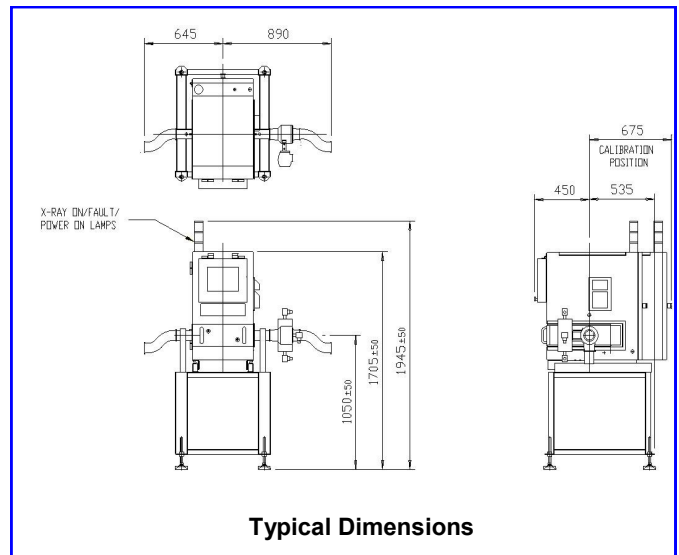

USA — Loma Systems, 283 East Lies Road, Carol Stream, IL 60188
Canada — Loma Canada, 333 Wycroft Road, Unit 11, Oakville, Ontario, L6K 2H2

Tel: 1-800-USA-LOMA
Tel: (905) 842 4581

Fax: (630) 588-1394
Fax: (905) 842 3460

Email: sales@loma.com
Email: lomacanada@loma.com